

DISTRIBUTOR/AGENT:	DATE OF ORDER:
	DATE OF DELIVERY:
	NAME OF THE ADDRESSEE/USER:



Product marked **CE**

### FEATURES

- **Ergonomic and modular tricycle** that helps the user to keep a proper posture and makes the ride easier thanks to its design and components.
- **Lowered frame** for easy ascent and descent.
- **Front positioned bottom bracket** for easier pedaling.
- **Optimized pinion** to facilitate the pedaling in safety.
- **Folding frame** to save space during transport.
- **Adjustable handlebar** in height, backward-forward and reversible.
- **Wide and ergonomic handles**, to increase comfort.
- **Bell.**
- **Front and back led lamp.**
- **Front brake with locking device** for ascent and descent, that can be operated by the lever either on the right or on the left side of the handlebar. The distance between the brake lever and the handlebar is adjustable by screw.
- **Adjustable ergonomic saddle** in height, tilt and backward-forward
- **Rear storage basket.**
- **16" pneus wheels.** A mechanism on the rear wheels allows easy adjustment of the tension of the chain.
- **Quick release front wheel.**



**Attention!**  
Read carefully the user and maintenance manual

Please check off the interested products:  \_\_\_\_\_

### MEASURES

FRAME COLOUR:

- Blue
- Red
- Green

Storage basket  
Internal measures

View from above

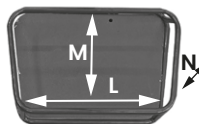

<b>L</b>	49,7 cm	In 19,5
<b>M</b>	27,4 cm	In 10,7
<b>N</b>	9,6 cm	In 3,6
<b>Max. Load</b>	25 kg	lb 55

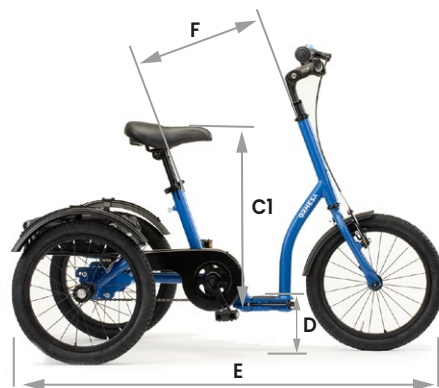

C1= C2-2cm

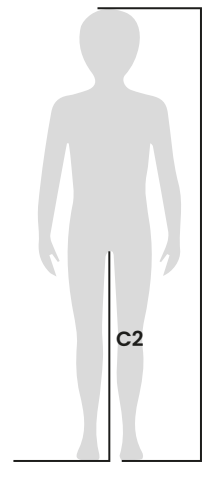

C2= leg length

	Max. Load	Aid Weight	A	B	C1*	D	E	F	G	I	User Height (H)
<b>Medium</b>	kg. 60 lb 132,2	kg. 23 lb. 50,7	cm 55 in 21,6	cm 75 in 29,5	cm 59-72 in 23,2-28,3	cm 16 in 6,3	cm 136 in 53,5	cm 45 in 17,7	cm 81 in 31,8	cm 90 in 35,4	cm 120-145 in 47,2-57

\*With standard saddle. You can further adjust the height of the saddle (± 3cm) acting on the clamp.

Choose the configuration

Fixed Pinion

Free Wheel

Differential and Fixed Pinion

Differential and Free Wheel

Three-speed transmission with differential. Allows braking by counter-pedaling, shifting when the tricycle is stationary, and reversing.

OPTIONAL COMPONENTS, ONLY CHOOSABLE WHEN ORDERING THE TRICYCLE

**864** Disc brake. only for models with differential and without gearbox.



Standard handlebar

S

M

Left

Right

Please choose the position of the brake. In the absence of indications, the brake will be mounted on the right.



**847** Cranks adjustable in length decreases the distance between saddle and pedal of 3,5 cm.



OPTIONAL COMPONENTS, ALSO CHOOSABLE SEPARATELY

**880** Ergonomic handles adjustable in inclination independently (1 pair). Same size as the Handlebar.

Choose the position of the brake on Ergonomic Handles



**845** Forearm support

Left

Right

mini

S-M



**875** Wrist retainer with support and multi-adjustable glove independently.

Left

Right

mini

S-M



**842P** Pelvic support with belt, adjustable in height. Also select the component 883

mini-S

M



**842T** Trunk support, adjustable in height, inclination and backward-forward with belt and joint. Also select the component 883

mini-S

M



**883** Rod adjustable in height for Thoracic/Pelvic support (single rod). Please select even the type of support.



**877** Flat backrest



**843** Abductive saddle with holder for supports



**876** Monocycle saddle with holder for supports



**840** Pedal cages with straps (1 pair).



**841** Pedal cage with length and width adjustable foot imprints and fastening straps, with support kit.

Left

Right

mini-S

M-L-XL



**846** Ankle support adjustable in height, with support kit. Only with component 841.

Left

Right

S-M

L-XL



**923** Additional assistant handle.



**963** Steering assistant handle adjustable in height.



**881** Steering limiter.



**882** Steering limiter with springs to return the steering to the straight position.



**879** Front basket.



**878** 878 MTB tires (3 pcs.) in alternative to standard tyres

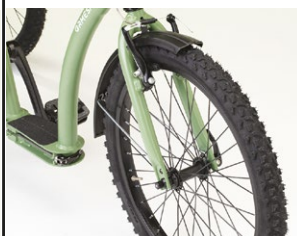

COMPONENTS MEASURES

**842P**

	A
<b>mini/S</b>	8,5-14 cm / in 3,3-5,5
<b>M</b>	8,5-21 cm / in 3,3-8,3
<b>L/XL</b>	8,5-23 cm / in 3,3-9

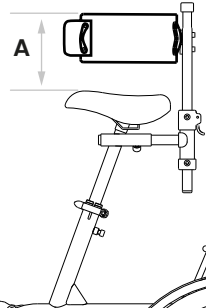

**842T**

	A
<b>mini/S</b>	19-30,5 cm / in 7,4-12
<b>M</b>	19-40 cm / in 7,4-15,7
<b>L/XL</b>	19-46 cm / in 7,4-18,1

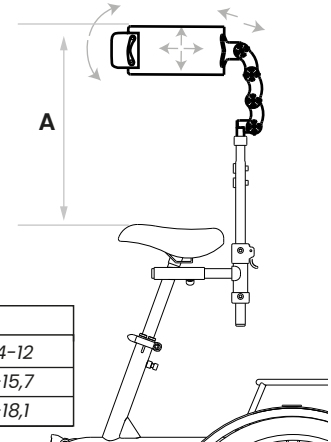

**842P - 842T**

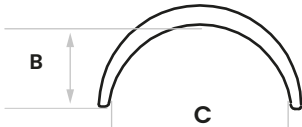

	B	C
<b>mini/S</b>	10,5 cm / in 4,1	23 cm / in 9
<b>M</b>	12,5 cm / in 4,9	31 cm / in 12,2
<b>L/XL</b>	17,5 cm / in 6,8	35 cm / in 13,7

**843**

	A	B
<b>mini/S</b>	31 cm / in 12,2	12,5 cm / in 4,9
<b>M/L/XL</b>	40 cm / in 15,7	14 cm / in 5,5



**876**

<b>A</b>	31 cm 12,2"
<b>B</b>	13,5 cm 5,3"
<b>C</b>	9 cm 3,5"

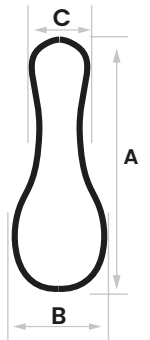

**841**

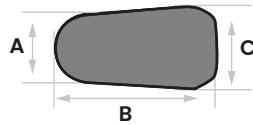

841 foot imprint size			
	A	B	C
<b>mini/S</b>	from 5 to 7 cm from 1,9 to 2,7 in	from 12,5 to 16,5 cm from 4,9 to 6,5 in	from 6 to 7 cm from 2,3 to 2,7 in
<b>M/L/XL</b>	from 8,2 to 9,4 cm from 3,2 to 3,7 in	from 20 to 22,5 cm from 7,8 to 8,8 in	from 10,4 to 12 cm from 4 to 4,7 in

**Standard handlebar**

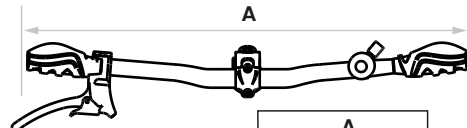

	A
<b>mini</b>	45 cm / in 17,7
<b>S</b>	50 cm / in 19,6
<b>M</b>	55 cm / in 21,6
<b>L</b>	60 cm / in 23,6
<b>XL</b>	64 cm / in 25,2

Notes:-----

-----

-----

-----

-----

-----

-----

-----

-----

-----

-----

-----

-----

-----

-----

-----

-----

-----

-----

-----

-----

-----